

CHEMISTRY	LITHIUM MANGANESE DIOXIDE
SYSTEM	PRIMARY Li/MnO <sub>2</sub>
MODEL	CR2430

**SPECIFICATIONS**

Nominal voltage	3.0V
Nominal capacity (@0.2mA, cut-off 2.0V)	280mAh
Continuous standard load	0.2mA
Operating temperature	-20°C / +60°C
Weight	4.5g

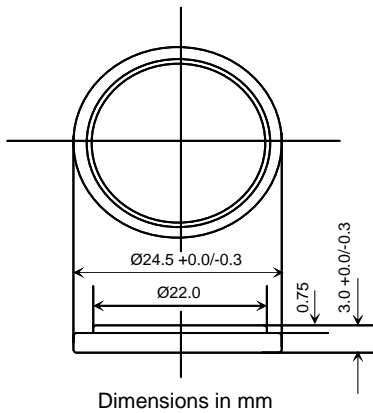

Standard and customized tab configurations are available upon request.

**WARNING:** DO NOT short-circuit, charge between "+" and "-".  
 DO NOT over-discharge, put in fire, disassemble.  
 Finish sealing less than 5 seconds at 200°C~250°C.  
 When the battery is discharged to cut-off voltage,  
 dispose of it in compliance with federal, state and  
 local laws or regulations.

